

## EFFICIENT ROLLER HEMMING AT EBZ

To program its roller hemming operations, EBZ has introduced the standard OLP solution for contour-guided robot processes: **FASTCURVE**.

### ► ROLLER HEMMING IN PROTOTYPE CONSTRUCTION

The use of roller hemming to process multi-layer sheet metal, e.g. for vehicle doors, engine bonet or trunk lids, is a cost-effective approach that's steadily gaining popularity in low- to medium-volume production, such as one finds e.g. in prototype construction. In contrast to traditional hydraulic or electrical hemming processes, roller hemming with standard industrial robot support allows for highly flexible guidance of the roller hemming head with its modeling rollers along the processing paths, the so-called hemming steps. Until the final process step, the metal sheets being processed are clamped into a tool bed.

Additionally, this space-saving hemming variant permits selective customization of the robot program, which in turn allows precise modification of dimensions and tolerances.

To allow the flexible roller hemming cell to work efficiently, offline programming has to enable quick implementation – both during programming and during later running-in.

The CATIA-integrated FASTCURVE is a high-performance offline programming system, making it the perfect solution for EBZ. No new functions had to be developed to enable roller hemming. The system lets EBZ work comfortably and easily with V5-based component geometries on surfaces, curves and points.

### ► PROGRAMMING WITH FASTCURVE

FASTCURVE was only customized with respect to the translators, adapting program output in line with specific EBZ requirements.

For programming purposes, the relevant components are loaded to the programming environment. Without conversion problems, the designers' CATIA V5 component data can be used throughout FASTCURVE processing.

Contours are generated simply by selecting them from the component geometry via a comfortable contour

search. Depending on the needs at hand, contours can be approximated linearly or circularly and enhanced by appropriate offsets. This guarantees harmonious robot movements, which in turn yield the first-rate surface quality that EBZ requires.

In any particular processing case, the specific programs that steer the hemming steps can be easily derived from the initial program. Thus, path copies only need to be updated with respect to offsets and tool orientation. As a result, any roller hemming program can be developed within minutes.

Following roller hemming simulation and thorough collision checks, the completed program can be read out and copied to the hemming facility. EBZ is content with the result.

### ► IMPROVED TIME EFFICIENCY AND HIGHER SURFACE QUALITY FOR EBZ

The programming solution has given EBZ numerous benefits. The application of robot-supported roller hemming is efficient, and FASTCURVE is a consistent system featuring a standardized approach.



# EFFICIENT ROLLER HEMMING AT EBZ

EBZ also profits from the enhanced surface quality of its products. Program generation is now faster, because less time is needed for model preparation and because the different hemming steps can be programmed more efficiently. "FASTCURVE saves us 70% of our programming effort", says EBZ's Samuel Krauß.

Flexibility and ease of programming also simplify production. Programmed robot paths can be deleted or modified at any time. Starting and end points can be selected freely along the paths and can be freely altered with respect to approach and disengagement movements. Events for additional guidance of program output can be inserted along the path, allowing flexible reactions to special circumstances or actions to influence dimension and tolerance thresholds.

From initial installation to production, CENIT AG provides the EBZ users with competent support.

## ▶ ABOUT EBZ

Engineering Bausch & Ziege GmbH – EBZ Group has been active in the global automotive industry for decades and measures its success against the high standards of the industry.

The enterprise covers the entire process chain of tool and plant construction, making it a one-stop shop for all steps from engineering to production to running-in of production facilities and forming tools.

EBZ Group is headquartered in Ravensburg. With more than 900 employees, the enterprise posts annual sales of approx. 140 million Euro.

[www.ebz-group.com](http://www.ebz-group.com)

## ▶ ABOUT FASTCURVE

DELMIA V5 Offline programming: FASTCURVE contains all essential CAD/CAM and simulation components to allow various processes to machine 3D contours.

## PRODUKTEIGENSCHAFTEN

- CAD functions and automatic clean-up for any type of geometry
- 3D solid and surface based modeling
- Powerful sketcher function to create 2D contours
- Full associativity between fixture and nested geometry
- Fast and easy alignment of the part using various calibration functions
- 

## BENEFITS

- Continuous process chain from modelling to offline programming using native V5 data
- Time saving through automatic fixture creation
- Time saving through less required prototypes
- Increased robot cell availability through obsolete teaching activities and shifting programming activities to FASTCURVE
- Robot simulation and collisionchecking before execution

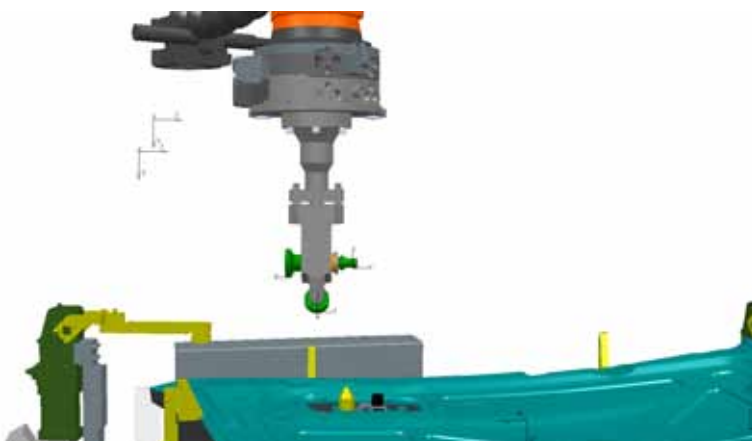

Quick and easy programming of roller hemming processes

## CONTACT

CENIT  
Industriestraße 52-54  
D-70565 Stuttgart

Phone: +49 711 7825-30

Fax: +49 711 7825-4000

E-Mail: [info@cenit.de](mailto:info@cenit.de)

Web: [www.cenit.de/en/FASTCURVE](http://www.cenit.de/en/FASTCURVE)